

TEST PLATFORMS OF LOX/ETHANOL ROCKET STEAM GENERATORS AT DLR LAMPOLDSHAUSEN

G. Krühsel, K. Schäfer

Institute of Space Propulsion, German Aerospace Center (DLR), Germany

Introduction

An altitude simulation test facility for rocket propulsion systems requires for a short time large quantities of steam to operate the ejector pumps. For this purpose rocket steam generators (RSG) are used for more than 30 years in DLR. The principle is to inject water into the hot gases produced inside a rocket combustion chamber and evaporate the water in a mixture chamber. The rocket steam generators make it possible to supply the required quantities of steam at short notice and reduced investment costs. However the rocket combustion chamber injection and combustion of propellants needs special attention of design and test efforts.

For the need of advanced altitude simulations with a maximum of flexibility and necessary cost reduction new RSG were developed. The concept of the new RSG is based on the combustion of Ethyl Alcohol and Liquid Oxygen ignited by H₂/O₂ pilot flame Igniter. Units with 4,5 kg/s, 10 kg/s, 40 kg/s and 55 kg/s steam are developed, tested and

taken into operation [1, 2]. Subject of this article is the comparative description of the two used test platforms for RSG development

- P1.1 Test Rig
- P4 Steam Generator Building

The P1.1 Test Rig

Arrangement of Specimen

The test bench has been erected 1994 and was used first for the 4.5 kg/s RSG prototype testing. The RSG are tested in two modes.

The combustion chamber mode is tested with integrated combustion chamber, injection head and expansion nozzle into the test rig (fig. 1). In this configuration the exhaust flame is visible and there is an easy access and inspection of the combustion chamber possible. An exhaust deflector cooled by water turns protects the concrete structure.

The second mode of operation is the nominal steam generator mode: The combustor is installed at the top of water injection with mixing chamber followed by the steam line and the ejector nozzle (fig. 2). In this mode the complete process of steam generation including

combustion of propellant, injection and evaporation of water is tested. The steam jet can be observed during test.



Fig. 1: Combustion Chamber Mode



Fig. 2: Steam Generator Mode

reservoir. The tanks are pressurized by GN2 which has been stored into 200bar GN2 bottles. This supply hardware is positioned next to the test rig of the RSG. Therefore the P1.1 bench has short propellant lines. Mass flow variation is provided by pneumatic regulation valves integrated inside each fluid lines.

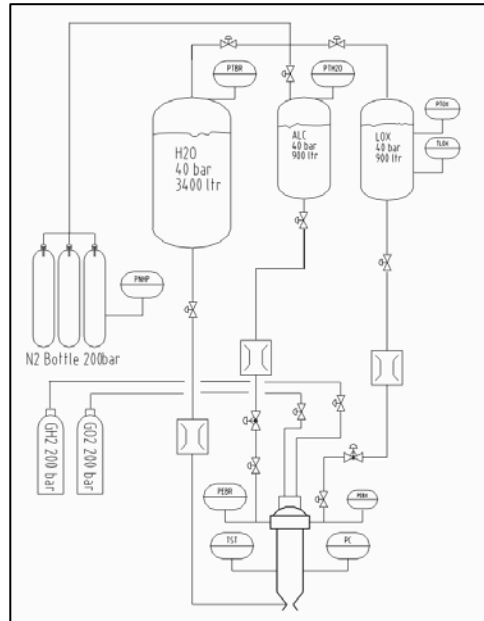

Fig. 3: P1.1 Fluid System

Measurement and control system of P1.1

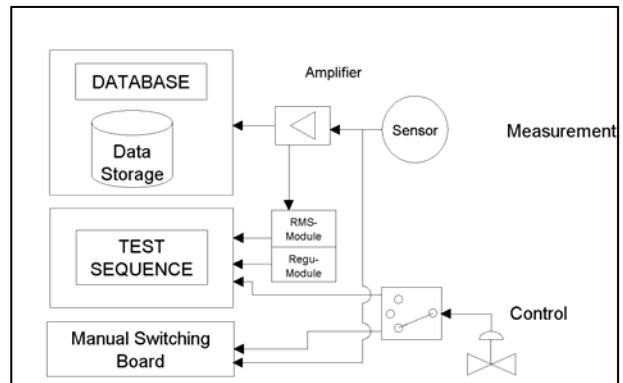

Fig. 4: P1.1 Measurement and Control

Fluid supply system of P1.1

Fig. 3 shows the schema of the fluid supply. Propellants and water are provided to the RSG by GN2 tank pressurization. Max supply pressure is 40bar inside the 0.9m³ LOX and Ethyl alcohol storages and inside 3m³ water

Fig. 4 shows a schema of measurement and control system of P1.1. These two functions are managed by different hardware systems. Control unit is a SIMATIC with two human interface units (touch screen). For event documentation a plotter connected to the SIMATIC prints out immediately status change of the command

system. Accuracy of command is about $\pm 10\text{ms}$ (cycle time of SIMATIC). The sequence is implemented into a flash able EPROM.

The command room contains control panel with buttons for starting sequence of the SIMATIC, video and intercom functions. A manual switching board with direct switching access to the bench valve allows de-coupling of SIMATIC from the bench. Also sequence check runs without switching valves on the test stand are possible. The measurement system consists of conditioning and acquisition system for lower and high frequency channels. The amplifiers are integrated into separated racks and can be adjusted and cabled (via patch panel) to different type of transducer. For redline implementation (RMS modules) and regulation function further hardware modules are present.

P4.1 Stem Generator Building

The P4 RSG building (fig. 5) has been erected in 2000. There are 4 RSG with about 55 kg/s steam each and one 16 kg/s unit to provide the necessary power for the steam jet

pumps of P4.1 and P4.2 altitude simulation.



Fig. 5: P4 Steam Generator Building

Fluid system of RSG at P4

The 4 x 55 kg/s RSG at P4 are supplied by pumps for LOX, alcohol and water. The 16 kg/s RSG is supplied by GN2 pressurisation of the run tanks for LOX and alcohol. Each RSG has a separated supply line. Fig. 6 shows the general arrangement of the RSG building.

There are two LOX and alcohol run tanks to supply 2 x 2 RSG parallel. Water is supplied by water storage inside P4.2 test facility (distance 100m). Length of steam lines is about 80m. The steam lines of RSG 1 and RSG 2 supplies either P4.1 or P4.2 test bench.

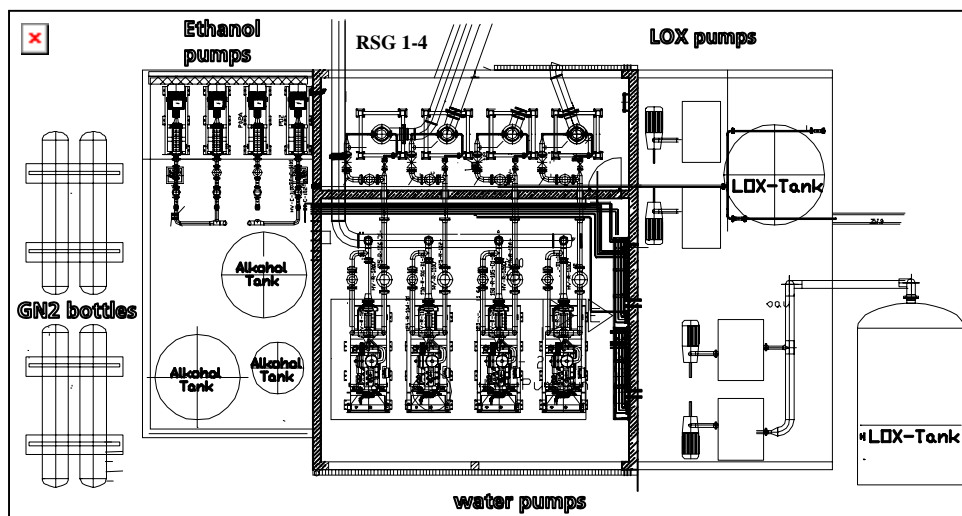

Fig. 6: P4.1 – Steam Generator Building

SESSION 5.13: DIAGNOSTIC TECHNIQUES

Operational points are seen in Fig 7. In brackets the values of the 16 kg/s RSG is mentioned.

Plants			P4.2	P4.1	
Test bench					
Units:			2*	2+2*	(+1)
	LOX	kg/s	8,2	10	(3,3)
	ALC	kg/s	4,0	4,8	(81,3)
	Water	kg/s	32,8	40,2	(11,4)
	Steam	kg/s	45	55	(16)
Maximum run time	s		1000	1000	(1500)
Steam generation	kg/s		80	220	(+16)
Steam pressure	bar		20	20	

*) 2 units selectable for P4.1 or p4.2

Fig. 7: Operational Parameters

Measurement and control system

Control of RSG operation is performed in the M8 command centre also used for P5 and P4 test bench control.

UNIX based workstations provides the platform for command and measurement (Front end / back end network). A database is a common kernel element for both measurement data and command sequences (Fig. 8).

Each measurement channel has got its own industrial standard analogue digital converter interface for acquisition of 4-20mA signals. Thus the nominal measurement channel consists of a sensor with integrated converter electronic (transmitter technology).

Test sequences are written in C derivate programming language. Similar regulation modules and RMS modules are software solutions and integrated into the database. Human interfaces are PC's working in terminal mode.

In case of main computer failure a second UNIX based emergency stop system (ESS) takes over the control of most important valves in order to shut down the RSG in save conditions.

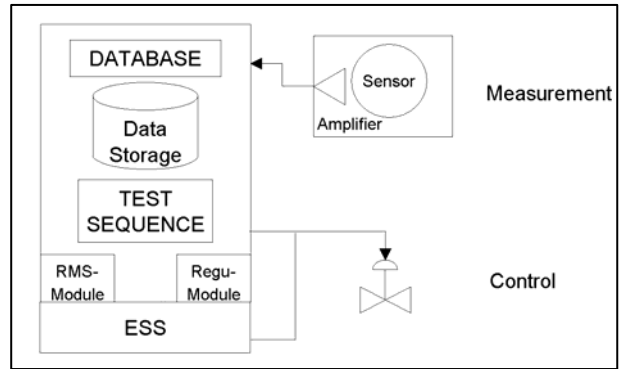

Fig. 8: Measurement and Control P4

RSG Testing at P1.1 and P4

After erection of P1.1 the first hot run were performed with a 4.5 kg/s SG unit prototype at 1994. The experiences were used for the design of the 10 kg/s RSG. This RSG is used at the P1.0 altitude test bench for satellite propulsion.

Further need of increasing mass flow results into complete redesign of injection head with a 28 kg/s RSG in 1997. This RSG prototype confirmed basic injector modification. The first 42 kg/s RSG prototype was installed and tested at 1999.

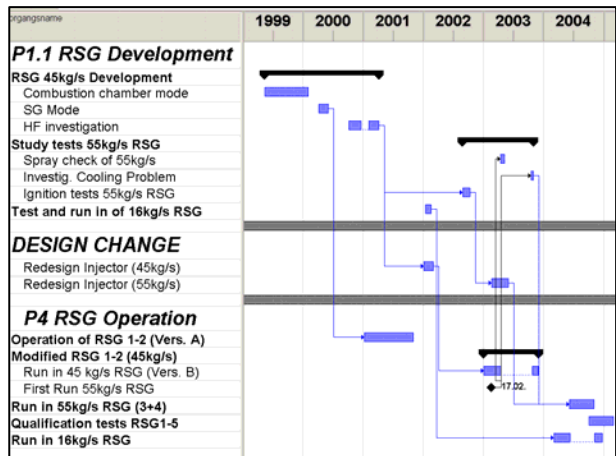

Fig. 9: RSG Development

Fig.9 shows the test and design history of RSG development for P4. 1999 and 2000 basic tests for 42 kg/s RSG have been performed at P1.1. HF combustion problems and their solutions have been investigated at P1.1. Results have been incorporated into the 42 kg/s injector

design by integration of baffles and adjustment of operational point.

By the increasing mass flows the P1.1 bench reached its design limit. The storages are limited the hot run duration for 60s with a 42 kg/s combustor. The main test activities were shifted directly to the P4 steam generator plant.

To minimize the run in phase of the RSG at P4.1 detailed investigation and hardware solutions were tested at P1.1 test platform. For example the first 55 kg/s hot run at P4 showed the cooling problem of the combustion chamber and resulted into spray tests and hot run tests at P1.1 for verification. Major advantage was the flexibility in term of time and hardware equipment of P1.1.

At the beginning of 2002 a short run in test campaign of the 16 kg/s RSG was performed at P1.1.

Main objective of P4 steam generator plant is the delivery of sufficient steam quantity for P4.2 and P4.1 bench operation. For this the RSG building had two erection phases.

The first phase was for the P4.2 altitude simulation of AESTUS engine. Mid of 2000 the 42 kg/s RSG design was frozen and two RSG units have been implemented into the new RSG building. The first erection phase was finalized by run in tests of two 42.5 kg/s RSG in 2001. They were serving P4.2 up to October 2001.

The second phase was for the P4.1 altitude simulation of VINCI engine. Within starting of P4.1 project the RSG building was extended by two 55 kg/s RSG and one 16 kg/s unit. After redesign of the injection head the final version of 55 kg/s RSG were installed and tested since mid of 2004. Parallel the tests of P4.2 were performed. Run in tests of the 55 kg/s units were finished third quarter of 2004. Total configuration with 226 kg/s steam production was first running on 14th of December 2004.

Nevertheless at least two specific development objectives could only reached at P4 RSG platform. First the long duration tests of 1000 s (compared to hot run of 60 s at P1.1) and second increasing the mass flow from 42 kg/s to 55 kg/s.

Tests with development objectives requested higher number of measurement channels than usual available for the operation. Measurement channels from two RSG test position at P4 had been re-cabled in order to fulfil the requirements. Specific extension of the highly industrial integrated measurement system was not possible. Especially for the necessary HF measurement the nominal RSG equipment had to be complemented by adding specific amplifier. The output signal was introduced into nominal amplifier interface (with amplification factor 1) of already existing measurement line. Time resolution of temperature and pressure transducer had to be improved. Infra red equipment was additionally installed and cabled in order to observe the combustion chamber wall temperature at high flow rate tests.

Test methods on P1.1

For specific problem understanding and solution verification hot run tests is the final proving step for hardware modifications. Thus it's necessary to monitor problem specific parameter during hot run.

Once identified sensor selection and implementation are performed and sensor line integrated into the full scale test specimen of P1.1 test platform.

Table 1 summarizes some important measurement technique applied at P1.1 in order to study and overcome design problems of RSG development

Table 1: Measurement techniques

Problem	Physical Subject	Measurement/sensor
HF combustion stability	Triggering	Bombing device at chamber wall
	Quarter wave tube absorber tuning	HF Transducer integrated into the cavity
	Baffles inside Combustion Chamber	HF Transducer near Faceplate inside each compartment
Repositioning Igniter	Ignition shock inside Chamber	Vibration transducer on Injector
	Flow start up and first injection	Digital high speed camera at water spray tests
Overheating of chamber wall	Wall temperature	External digital infra red camera

Study of quarter wave tube absorber

Quarter wave tube absorbers are usual passive damping devices for suppression of HF oscillation inside a combustion chamber [3]. An adjustable absorber ring was designed and tested at P1.1 in 2000 (fig.11). For details of operation see [1]. Precondition for hot run measurement was the integration of HF pressure transducers inside the absorber in order to determine the tuning point of the absorber. One HF pressure transducer has been installed at the backward wall of the cavity. Another

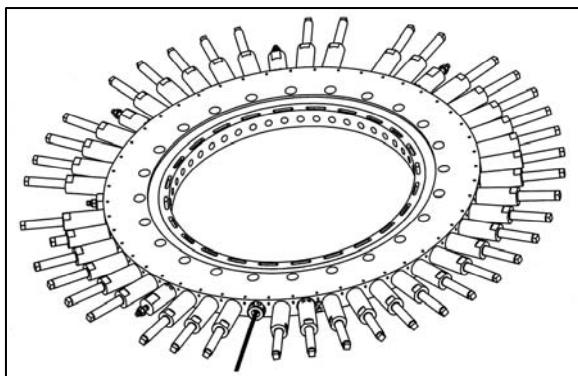

HF transducer has been installed at the next cavity plane with the chamber wall.

Fig. 11: Absorber Ring

Calculating the transfer functions of the two signals shows the variation of the tuning point of the cavity during hot run (Fig. 12).

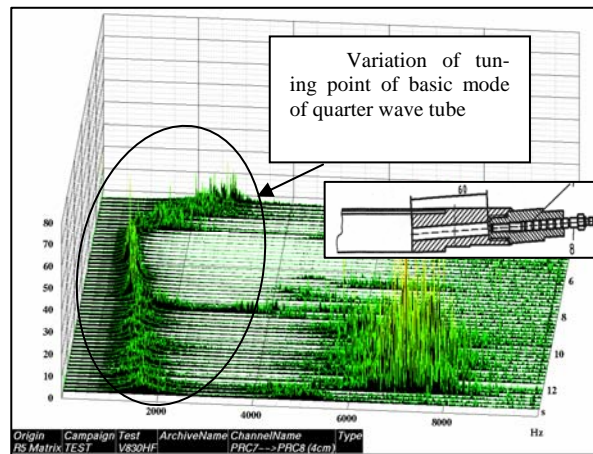

Fig. 12: Results Quarter Wave Tube

Baffles inside combustion chamber

A prototype baffle was designed and installed inside the combustion chamber (Fig. 13). For triggering pressure oscillations a little pyrotechnic charge has been installed inside the chamber and ignited during hot run. A HF pressure transducer integrated into the chamber wall registered the pressure evolution in order to look for damping conditions inside the combustion chamber.

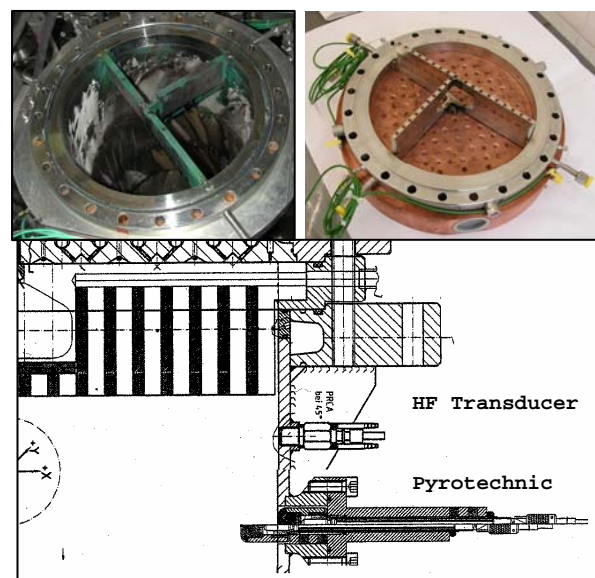

Fig. 13: Baffles

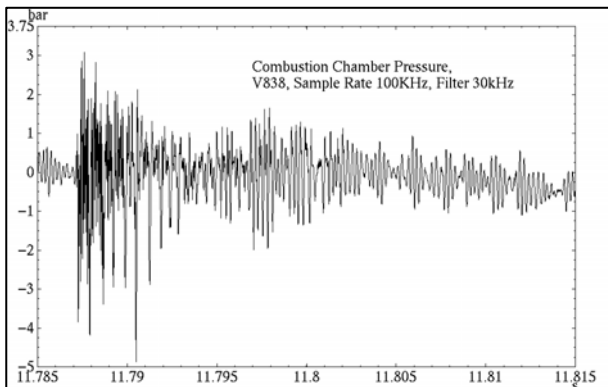

Fig. 14: Bomb Test

Fig.14 shows a result of such test with decreasing oscillation after ignition of the pyrotechnic. In contrast to the cavity ring tests the baffle proofed damping conditions in hot run test. The concept of a three blade baffle was first introduced into the RSG 1 and RSG 2 at P4 at 2003.

Chamber cooling

Increasing mass flow of the RSG from 45 to 55 kg/s at P4 tests resulted into over heating conditions on the chamber wall. Due to single wall design of the chamber an infrared observation of the chamber wall surface has been performed first at P1.1 (Fig.15).

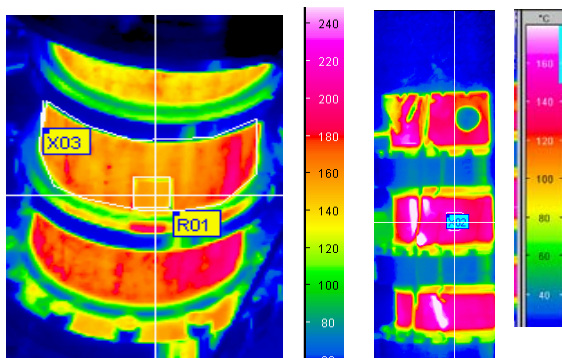

Fig. 15: Infrared Observation Wall

Thermal foot prints of injection elements are observed when combustion gases rich of oxygen are contacting the wall. Modification of flow rate of ethanol and LOX during hot run showed effects onto wall temperature in order to give indications for further adjust-

ment measure. The tests resulted into installation of LOX injector orifices at the entrance of each like on like doublet element in order to control oxygen cross section distribution. Today this orifice is part of nominal configuration of RSG at P4.

Water spray studies in context with Igniter re-positioning

First version of injection head had got a central positioned GH2/GOX Igniter firing along the centre line of the combustion chamber. This design was critical because of the complex penetration through the injection head. Furthermore the feeding of LOX was asymmetric which was found to be unfavourable with the selected small volume of the LOX dome. Next the baffle inside the combustion chamber requested a revision of Igniter position.

For this reasons a sideward Igniter position was considered. In this case the Igniter is integrated inside the chamber wall and is operating transverse to the propellant flow. In order to minimize the ignition shock unburned propellant should be reached as early as possible. Therefore knowledge of transient spray formation is important. DLR performed water spray tests with digital high speed camera observation (2000 frames/s) in order to simulate and study start up conditions of fuel flow.

Figure 16 show some start up images. The pictures are shown as negatives. Image A shows starting ejection of water at the outer row of the fuel doublets. Image B shows non atomized liquid sheets just before disintegration. After disintegration this liquid sheets are forming groups of large droplets. With further increase of injection pressure the droplets becomes smaller.

With sideward positioned Igniter the situation of image C becomes the starting condition of ignition. The study results helped to find a new Igniter position.

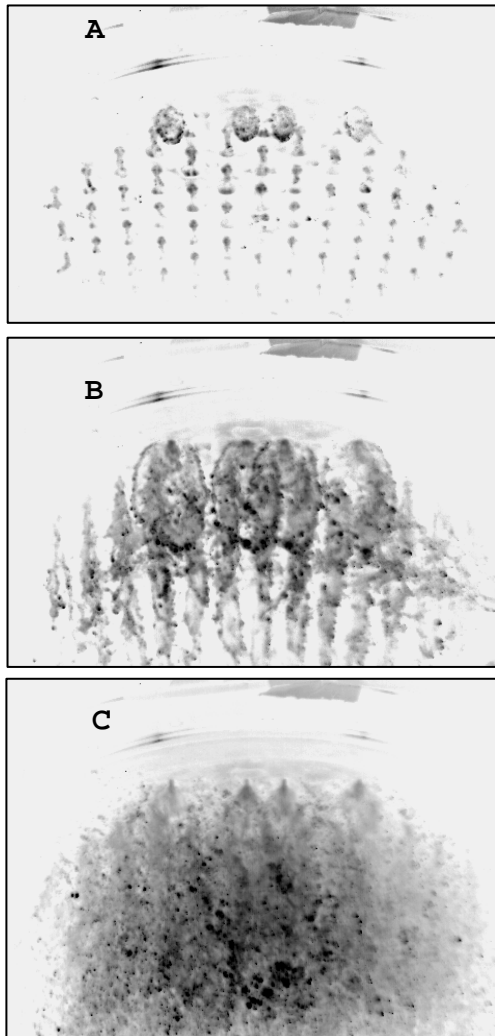

Fig. 16: Spray Images

Conclusion

A long term development effort starting with a 4,5 kg/s RSG prototype on 1994 cumulated into new P4 RSG building equipped with 4 x 55 kg/s RSG units.

Major basic development tests were performed at P1.1 test platform. The size and availability of a specific test tool like the P1.1 test benches allowed the evolutionary progressing design of the RSG. Valuable test techniques were trained and used for hot firing proof of hardware modification. However with the 55 kg/s RSG the bench P1.1 reached its limit and for further progress development

specific objectives have been implemented into run in tests of P4 RSG building. The status of the RSG building drives the progress in reaching the objectives of duration and flow increase. If possible specific problems were investigated at P1.1 test rig.

DLR has implemented a central data analysis data base (ZAS) where all test data from different test benches can be stored and addressed for further analysis. Equipped with a modern data analysis tool the ZAS system was most valuable tool for quick and comparable data analysis. Dense test documentation together with the ZAS assured that during a long term period the hot run data kept their value.

Fig. 17 summarizes the hot runs of RSG at DLR in Lampoldshausen in context with the P4 RSG (status May 2005). The run times are cumulated duration of each RSG.

	RSG 16 kg/s	RSG 42 / 55 kg/s
Total Run Time	15119 s	42157 s
Run in tests P4	7825 s	26139 s
Development P1.1	500 s	1105 s
Operational Time P4.2	NA	4886 s
Operational Time P4.1	7294 s	11132 s
Number of hot run P4	75	
Number of hot run P1	6	68

Fig. 17: Hot Runs RSG

References

1. Krühsel G., Schäfer K. "Design and Development of an Ethanol/LOX Injection Head for Rocket Steam Generator (45 kg/s Steam) and Experimental Study of Combustion Stability", Fourth International Conference on Green Propellants for Space Propulsion ESA SP-484, 2001, pp. 275-282.
2. Krühsel G., Schäfer K. "Design, Development and evolution of an Ethanol/LOX Injection Head for Rocket Steam Generator of High Flow rate" AIAA 2003-5044
3. Laudien E., Pongratz R., Pierro R., Preclik D. Instability Suppression Mechanisms, DASA-Z- 0478-93-PUB, 1993