

# PERSEUS

## European Space Research Program for Students

*Hélène Hingre\*, Jean Oswald\*\*, Anne Galéon\*\**

*\*MI-GSO : 40, avenue Morizet, F-92100 BOULOGNE-BILLANCOURT*

*[hhingre@mi-gso.com](mailto:hhingre@mi-gso.com)*

*\*\*CNES : Launcher Directorate, 52 rue Jacques Hillairet, F-75012 PARIS*

*[Jean.Oswald@cnes.fr](mailto:Jean.Oswald@cnes.fr); [Anne.Galeon@cnes.fr](mailto:Anne.Galeon@cnes.fr)*

### Abstract

The PERSEUS project provides the opportunity for motivated students to pool their knowledge to the development of space launchers vehicles. Their applicative work refers to a subscale of a Nano Satellite Launcher which corresponds to an experimental rocket. They can work either through the classical pedagogic frame proposed by their university, either in a space association or as researchers in a laboratory. The CNES, with the help of its PERSEUS partners, is coordinating all these activities in order to achieve a complete life cycle of prototypes : objectives, studies, development realization, reviews, ground or flight test and exploitation.

### 1. Introduction

PERSEUS is a french acronym for “Projet Etudiant de Recherche Spatiale Européen Universitaire et Scientifique”. The PERSEUS project was launched 10 years ago [8]&[9] by the French Space Agency. It was organized on three main objectives.

The first one is innovation and testing promising technologies applicable for space launch system.

The second is to rely on students to practise the first objective and, at the same time, to keep their motivation for space through their graduation.

The third objective is to provide a frame to students which enable them to build a set of ground and flight demonstrators in order to confirm or disprove the technology potential.

A first phase up to 2009 enabled to select the most attractive demonstrators which would gather students and eight partners. Then in order to progress on these ground or flight demonstrators completion, a first agreement was signed for five years [3]. Due to the success of this organisation, in 2015, a new agreement (also five years duration) was signed with twelve partners (AJSEP, Bertin Technologies, GAREF, HERAKLES, IPSA, ISAE-Supaero, MI-GSO, ONERA, Planètes Sciences, ROXEL, UEVE). The number of students who get involved every year is about 250. They are mainly involved through pedagogic activities and can extend their participation through space association within their university. An integrated team (EPIP) located at Evry University (UEVE) coordinates all the activities.

### 2. The PERSEUS network

Twelve partners have signed this agreement with CNES. Some groups can be identified, Universities (IPSA, ISAE-Supaero and UEVE), space associations of experimented amateurs (GAREF and Planètes Sciences), some small and medium enterprises (Bertin Technologies, MI-GSO, ROXEL), an institution (ONERA) and even an industry, HERAKLES, through the AJSEP association, has joined the project. Partner’s members within or in association with the integrated team provide an efficient support to the teachers in charge of the students supervision.

An adaption of the management rules used in space industry has been carried out for the student projects. These management rules teach the students that a minimum of documentation is required by a review group at predefined date. The required documentation must be compliant with the pre-set level of realisation of the demonstrators for this

date. The levels range from the objectives, preliminary definition, critical definition qualification, flight up to of course flight data exploitation. Despite a special attention from the PERSEUS project, this last point which is essential to correctly define the new objectives is unfortunately not deeply analysed by students.

The PERSEUS project has a large turnover of students, this was chosen to promote innovation with purpose, but the counterpart is that a lack of knowledge about launch system constraints is obvious. In order to reduce this drawback, the PERSEUS project has developed specific spots:

- Several formations are given to the students, specially about management, organization (MI-GSO) and system loop and electrical integration (GAREF)
- The teachers in university and the lead students in association are invited to transmit their knowledge to the new generation in order to progress on the demonstration realizations rather than starting from zero each year!
- A collaborative portal (hosted by MI-GSO partner) is dedicated to documentation, reference documentation as well as working documents accessible to all the PERSEUS community.
- At last in complement to demonstrator realizations an annual seminar is held at Paris in winter, where all the students are invited to present their own work (oral and poster forms) to the industrial and scientific community. So they can understand easily their contribution to the global project and defend their work face to senior experts.

In complement of the main contributors to the PERSEUS project which are the partners, a lot of students outside the partner's universities are working for PERSEUS. Each university or French high school has its own application of the pedagogic project. They can contribute to testing isolated technologies or developing parts of the demonstrators. The coordination at the PROJECT level of all these entities is performed by the integrated project team (EPIP) led by CNES.

### 3. Flight demonstrations

The flight demonstration is the most impressive realization of the PERSEUS project. Two launch system families are investigated in PERSEUS, the classical launch from ground and the airborne launch.

#### 3.1 From subsonic regime with ARES

Each year, some university associations are working beside pedagogic project in order to develop experimental rocket, named ARES [2]. Almost 20 rockets (diameter 160 mm, height 2.5 m and MTOW between 15 and 20 kg) were launched over the last 10 years, mainly during the French National campaign called C'Space organized by CNES.



Figure 1: ARES launch at C'Space

Two rockets were also launched in the Netherlands in cooperation with DARE students from Delft University. The development of these ARES rockets is coordinated by IPSA partner. These rockets were propelled by small hybrid engines at the beginning and then replaced by solid Cesaroni engines.

Step by step, a global architecture, and an exhaustive avionics, was developed, improved and operated by students. The GAREF partner is among else in charge for the ground installation and telemetry. The structural consistency of these rockets was verified by using a mechanical test bench which can generate loads on the structure which intensity is a direct result of global loads analysis. The work performed by Scube, OCTAVE and AeroIPSA student associations from ISAE-Supaero, UEVE and IPSA can be highlighted.

These demonstrators reach an altitude of 2 km and a subsonic Mach number of 0.6. These regular launches enable to test a lot of technologies such as:

- Sandwich composite structure for the structure and the fins, a patent was filed
- Aluminum 3D additive process with laser fusion for fins, or rocket top head including pressure canals [4].
- Thin circular antenna for full 3D clear emission of telemetry
- Roll control tested with canard fins

### 3.2 To supersonic regime with SERA

Based on this constant progression, our students worked on the SERA-1 rocket [1]. This project was coordinated by Bertin Technologies partner. A payload developed by students from Luleå Technology University from Sweden was embedded. It was launched in May the 7th 2014 in Kiruna from the polar base of the Swedish Space Corporation (SSC). The altitude reached is 5 km with a maximum supersonic Mach number of 1.3.



Figure 2: SERA integration before packing to Sweden

This performance enables to demonstrate that the PERSEUS project masters the classical dimensioning cases encountered for the development of an operational space launcher during its atmospheric phase, that is to say: lift off,  $Q_{max}$ , transonic regime and acceleration not higher than 10g.

### 3.3 Airborne launch

#### The composite EOLE / RSS / ARES

Following previous CNES/ONERA studies on airborne launch with the purpose of optimizing the global system a lack of modelisation of the separation and release system of the rocket from the carrier was identified. So it was decided to have a carrier, named EOLE, in order to be a flying test bench for release and separation system (RSS) which could be developed by students.

This project is coordinated by ONERA partner. EOLE was built and piloted by an experimented small company Aviation Design [5]. The RSS was defined and build by UEVE. The rocket developed in order to be carried by EOLE is an adapted ARES type rocket, developed in cooperation with students from CLC, GAREF and IPSA. The

EOLE span is 6.7m, propelled by two AMT Titan turbojet of a 40daN thrust. The maximum payload weight is 43 kg for a MTOW of 150 kg. A patent was filed.

Under the authority of the French DGAC, The EOLE carrier has performed several visual flights with and without the ARES rocket at the Saint Yan aerodrome in the centre of France. The last flight was performed in full automatic mode except the remote piloted take-off and landing. The next step is to perform the flight at 20 km from the runway and 4 km of altitude in order to be able to automatically release the rocket and ignite it safely.



Figure 3: EOLE carrying an ARES rocket

Some discussions are still pending with the compatible launch site, which should result on an agreement for this global demonstration, opening the way for other tests on future separation and release system developed by students.

### Remote piloted aircraft

Beside the EOLE large demonstrator, at a smaller scale a lot of experiments more open to students can be undertaken. This project is coordinated by Planète Sciences Partner. The purpose is to operate remote piloted airplane in order to test the release of a mini rocket in automatic mode. Despite the small scale (3 m wingspan) of these demonstrators the compliance with the regulation in force is imposed. The payload weight is 4 kg.



Figure 4: Mini remote piloted aircraft

## 4. Propulsion

At the beginning of PERSEUS project hybrid propulsion was developed and used for flight. Several rockets were launched with this propulsion [6]&[7]. But due to major directives, it was decided to stop hybrid propulsion at the PERSEUS project level in 2013 and to switch to commercial solid engines or bi-liquid propulsion.

### 4.1 Commercial rocket engine

Currently, the rocket demonstrators launched with the PERSEUS project use solid propulsion. They are commercial Cesaroni engines: Pro54-5G, Pro75-3G or Pro98Green3-6G. The operation of these engines is restricted to pyrotechnician which guarantees the safety. Some tests are performed at ONERA in order to check the operations and at the same time the thrust integral and the ignition delay. The main interest of using these engines is to have cheap propulsion on a single stage rocket which allows a part of the PERSEUS project to focus on structure, avionics,

operation and exploitation of the experimental rockets waiting for more suitable propulsion to improve performance. Moreover the improvement of ARES rocket performance, by developing two stages rocket for instance, would be feasible when the ignition delay of these engines will be completely mastered.

#### 4.2 Bi-liquid propulsion: LOx-Ethanol

The first bi-liquid engine built is a classical bi liquid engine using liquid Oxygen and Ethanol, able to propel an evolution of ARES rocket up to 10 km. This MINERVA project is coordinated directly by the PERSEUS integrated team. The purpose of the selection of the first engine technology was to demonstrate the ability of the PERSEUS project to perform fire test. So, classical triplet injectors (F-O-F) were designed in order to atomize the fuel and oxidant mixture in a chamber insulated with ablative protection. The rate flow of the 7 injectors was defined in order to have a 5 kN engine thrust. The estimated chamber pressure is fixed at 10 bar and the combustion time is 20 s. The estimate efficiency is 0.95 for a vacuum ISP of 295 s.

Three parts were separately developed. The ground facilities consisting in two Skids were built and are operated by the ROXEL Partner. One Skid is dedicated to Lox feeding another is dedicated to alimentation of Fuel. Both were developed with the support of the CNES R&T department. These two skids have been qualified and are waiting for the engine. The third part which is the engine itself was defined through a synthesis of student works. The achievement was made entirely by a small enterprise (STIM) which has contributed by its expertise to the finalization of a design compatible with the conventional manufacturing processes.

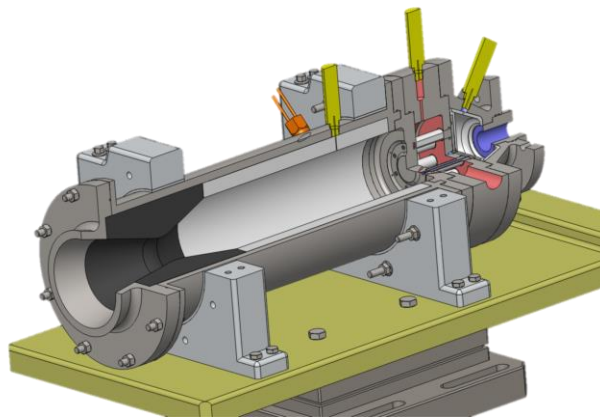

Figure 5: Overview of the first biliquid engine for ground fire test.

Several water tests were performed at the Martel facilities in Poitiers. These rather simple tests enable to check the correct rate flow, the mixing plume shape and any leakage in the injection dome.



Figure 6: water test of the injecting plate.

The next step is ignition and fire tests themselves which are planned for the end of 2015.

Depending on the success of these tests, several options can be foreseen: optimization of combustion, testing the definition of a new injector, designing a flight version...

## 5. Propulsive structure

A specific activity, PEGASE, is performed within the PERSEUS project in the Bordeaux area. The AJSEP Partner linked to HERAKLES partner is coordinated it. They are working on tanks and on the various parts of the solid engine. One can notice that an important supervising was offer in that case at the school project level, which leads in significant results: a tremendous progression of the devices (tank, combustion chamber, nozzle, insulated protection,...) defined and built by the students each year. The high level management was expressed through competition between projects on same objectives but with different constraints (economical, weight and innovation).

### 5.1 Tanks

The tank activities are the continuation of the previous works performed on hybrid propulsion where composite tanks for oxidant were already developed. This knowledge was kept and now applied to fuel and oxidant tanks for biliquid stage. A tank potentially candidate for Lox storage on this stage was already built by students and should be tested by ROXEL partner in order to verify the compliance with Lox during the whole life cycle. But a too high level of leakage postponed of one year the test on a new exemplar of tank.

### 5.2 Propellant mass ratio

The purpose of these activities is to optimize the propulsive stage in order to reduce the propellant mass ratio. The starting point is the existing solid stage. It is a serious pedagogic objective, which enables development of firing test structures which will be operated by ONERA. In this facilities new combustion chamber, nozzle and internal insulation developed by students will be tested.

## 6. Avionics

Early in the PERSEUS project, the first rocket demonstrators had their own launch electrical architecture based on the knowledge of individual contributors, which seemed rather promising with respect to innovation. But the main drawback is that it was difficult to keep alive all these architectures through the turnover of students. Finally, from 2012, an electrical architecture driven by the GAREF partner was selected. The main features of this architecture are:

- Telemetry at 2,235GHz with 1Mb/s rate compatible of professional launch site such as Kiruna in Sweden or Kourou in French Guyana
- Two IMU with MEMS enabling 3D measurements : accelerations, gyrometers, magnetometers
- GPS is also available but the loss of signal at lift off due to high acceleration rate must be bypassed before using it properly.
- On board experimental measurements such as pressure, temperature, vibration, acoustic,...sent by telemetry in the limit of the capacity of the bandwidth
- Precise datation up to 1/1000s of each event
- Non-intrusive detection of ignition order
- USB and RS485 on board network
- Command of each event
- On board batteries
- A set of ground installation in order to check the rocket behavior during the chronology, including the hot count down.

This architecture has the advantage that students can easily contribute and can propose evolution. They have appropriated this architecture. Moreover, a lot of specific measurements can be performed during flight in order to investigate a specific physical phenomena (aerodynamic, thermic, ..) . This architecture was optimized and used for the SERA 1 flight. Two tests were performed in order to check the robustness of the device to flight constraints and avoid any bad surprise during the SERA-1 supersonic flight. The flight electrical heart device was submitted to sinusoidal and vibrational tests and also to static load tests on centrifuge facilities.

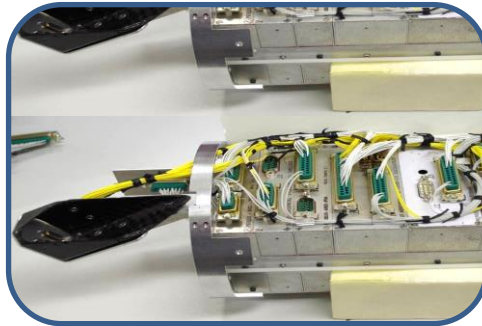

Figure 7: the electrical heart of SERA-1

In order to completely fulfil the main objectives of the PERSEUS project, the development of a new electrical architecture was initiated. As the architecture already exists, a first step will be dedicated to analyze with serenity new available technologies compliant with a future innovative electrical architecture.

## 7. System Studies

Since the very beginning of PERSEUS, system studies have been developed to perform preliminary design of nano-launcher concepts and associated performance. These studies include the development of tools for the simplified design of a launch system: stages, propulsion, aerodynamics, trajectory, global loads, structures... The studies that are completed through this calculation have to be transformed into consolidate data through more detailed studies or realizations. A check loop is then performed to confirm the concepts. Technical specifications for any PERSEUS realization always come from these system studies, called ULYSSE, which guarantee the technical coherence of the project.

Indeed, in order to compare innovative launcher concepts, PERSEUS has developed trajectory calculation software. It is widely used by the PERSEUS project team and also by some students, giving the opportunity to simulate and optimize all kinds of launcher or suborbital rocket trajectories,

For every launch, safety studies are carried out. Using PERSEUS tools, it defines the likely fallout areas of a demonstrator after its flight, in order to secure the launch site. A parametric analysis based on mass, aerodynamic, propulsion dispersions is performed and also wind for the fall down phase. For example, SERA1 safety calculation confirmed the accuracy of its model. Indeed, the demonstrator fell down at about 100 m from the estimated impact area. This accuracy was possible due, in particular, to the good knowledge of the winds at ground and altitude levels which were provided by the Esrange Space Center the day before.

Since 2010, ULYSSE has been developing tools enabling to analyse flight data. These experimental data are compared to simulated data performed for conception, system performances or safety studies. A tool dedicated to flight data post-treatment is developed under SCILAB. Its first version, improved with SERA1 flight data, is now available and will be enriched soon.

## 8. Conclusion

The PERSEUS project has developed a network of heterogeneous partners gathering youths and experts, associations and industries. This network has generated significant demonstrators (SERA-1, EOLE, MINERVA). These demonstrators were finalized mainly because the space dream can express itself through student's activities relayed by the supervision of the teachers, engineers and senior experts.

All the part of the launch system are analysed, developed and tested within the PERSEUS project. Structural, propulsion, avionics, etc...The performance of the demonstrators which are in constant progression is also a good way to keep this project attractive for students.

The number of partners (university or industry) could be increased in order to provide more stable contributions to the PERSEUS project to enable more complex realizations.

Web site: <http://www.perseus.fr>

Contact: [perseus@cnes.fr](mailto:perseus@cnes.fr)

## 9. References

- [1] C. Dupond, S. Pernon, J. Oswald - SERA 1 the first supersonic rocket developed in the frame of perseus project – In : *22<sup>nd</sup> ESA PAC Symposium* – Tromsø, Norway
- [2] C. Dupond, S. Pernon, J. Oswald - ARES rockets demonstrators of French Space Agency PERSEUS project – In : *21<sup>nd</sup> ESA PAC Symposium* – Thun, Switzerland
- [3] H. Hingre, R. Bec, J. Oswald, S. Pernon - European University and Scientific Space Research Program PERSEUS (Projet Etudiant de Recherche Spatiale Européen Universitaire et Scientifique) – In *4<sup>th</sup> EUCASS 2011* - Saint Petersburg, Russia
- [4] J. Korwin, B. Hugues - ARES EVE5 : an OCTAVE's experimental rocket for PERSEUS project – In : *65<sup>th</sup> IAC, 2014* – Toronto, Canada
- [5] J. Ledogar, J. Hermetz, H. Sohler, J. Oswald, E. Rantet - EOLE, an innovative flying test scale demonstrator for air-launch-to-orbit autonomous systems – In : *28<sup>th</sup> ICAS, 2012* – Brisbane, Australia
- [6] – F. Laurendeau, W. Pollet - Flight thrust modulation using hybrid propulsion system – *62<sup>th</sup> IAC, 2011* - Cape Town, South Africa
- [7] M. Prevost, P. Prevot - Design and development at ONERA of a hybrid rocket motor – *48<sup>th</sup> Joint Propulsion Conference, 2012* – Atlanta, USA
- [8] J.-M. Astorg, R. Bec, C. Bernard-Lépine, K. de Groot, F. Amouroux – PERSEUS A Nanosatellite Launch System Project Focusing on Innovation and Education– *58<sup>TH</sup> IAC 2007* - Hyderabad, India.
- [9] R. Bec, C. Bernard-Lepine, K. de Groot and F. Amouroux - PERSEUS A Nanosatellite Launch System Project Focusing on Innovation and Education - *2<sup>nd</sup> EUCASS 2007* - Brussels, Belgium

## 10. Acronyms

**3P** : Plateau Projet PERSEUS  
**AJSEP** : Association Jeunesse Sciences Espace Passion  
**ARES** : Advanced Rocket for Experimental Studies  
**CLC** : Space Association of Students from Ecole Centrale de Lyon  
**EPIP** : Equipe Projet Intégrée PERSEUS (PERSEUS integrated team?)  
**IMU** : Inertial Measurement Unit  
**MEMS** : MicroElectroMechanical Systems  
**MINERVA** : Moteur INnovant Experimental pour les Recherches sur les Véhicules Aérospatiaux  
**MTOW** : Maximum Take Off Weight  
**OCTAVE** : Space Association of Students from UEVE  
**PEGASE** : Projet Etudiant Girondin Activités Sciences Espace  
**PERSEUS** : Projet Etudiant de Recherche Spatiale Européen Universitaire et Scientifique  
**RSS** : Release and Separation System (DSL in French)  
**SERA** : Supersonic European Rocket ARES  
**SCUBE** : Space Association of Students from ISAE-Supaero  
**STIM** : Société de Tolerie Industrielle et Mécanique  
**UEVE** : Université d'Evry Val d'Essonne  
**ULYSSE** : Ultimate Liquid hYbrid Solid launch System Evaluation